

bw

BRUNO WESSEL

SATSIM

Semi-Automatic
Tire Stud Inserting Machine
OWNER'S MANUAL

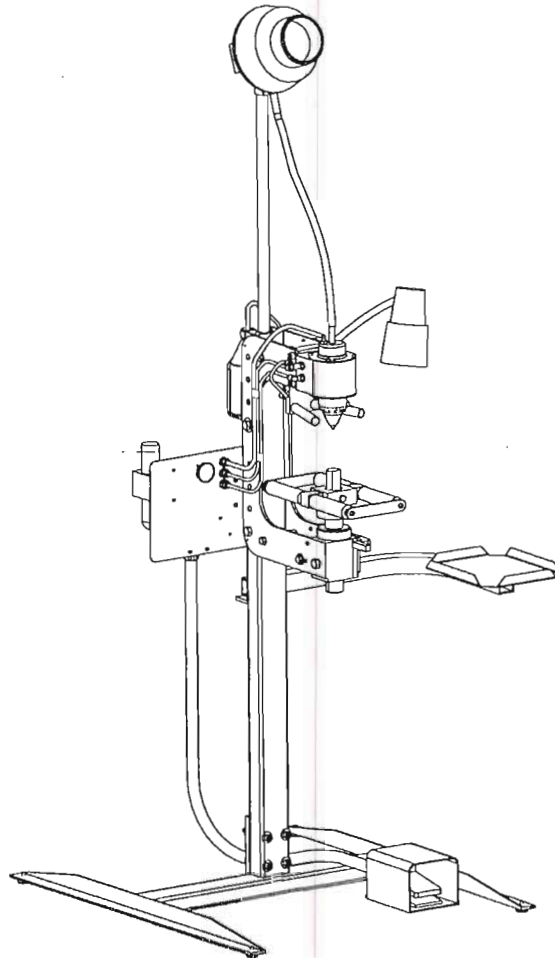

IMPORTANT SAFETY INSTRUCTIONS

Your new SATSIM comes equipped with an electric motor to operate the stud feeder.

Please read through this operating manual carefully before using your new SATSIM. Pay close attention to all Safety Instructions. Use this machine only for its intended purpose.

1. Read all instructions.
2. Care must be taken as burns can occur from touching hot parts.
3. Do not operate equipment with a damaged cord or if the equipment has been dropped or damaged - until it has been examined by a qualified serviceman.
4. Do not let cord hang over edge of table, bench or counter or come in contact with hot manifolds or moving fan blades.
5. If an extension cord is necessary, a cord with a current rating equal to or more than that of the equipment should be used. Cords rated for less current than the equipment may overheat. Care should be taken to arrange the cord so that it will not be tripped over or pulled.
6. Always unplug equipment from electrical outlet when not in use. Never use the cord to pull the plug from the outlet. Grasp plug and pull to disconnect.
7. Let the equipment cool completely before putting away. Loop cord loosely around equipment when storing.
8. To reduce the risk of fire, do not operate equipment in the vicinity of open containers of flammable liquids (gasoline).
9. Adequate ventilation should be provided when working on operating internal combustion engines.
10. Keep hair, loose clothing, fingers, and all parts of body away from moving parts.
11. To reduce risk of electric shock, do not use on wet surfaces or expose to rain.
12. Use only as described in this manual. Use only manufacturer's recommended attachments.
13. **ALWAYS WEAR SAFETY GLASSES.** Everyday eyeglasses only have impact resistant lenses, they are NOT safety glasses.

SAVE THESE INSTRUCTIONS

SATSIM

Semi-Automatic Tire Stud Insertion Machine

Thank you for choosing a Bruno Wessel product.

Your new SATSIM is designed and built to Bruno Wessel's demanding specifications for dependability. We have earned a reputation for producing high quality, innovative and durable tire studding equipment.

Please take the time to read this owner's manual and pay particular attention to the safety and maintenance instructions.

Table of Contents

Page(s)

Safety Instructions	2
Assembly Instructions	4, 5
Assembly Breakdown	6
SATSIM Maintenance	7
Operating Instructions	8, 9
Head & Spray Guide Assembly Breakdown	10, 11
Push Rod Style Assembly Breakdown	12, 13
C-Frame Assembly Breakdown	14, 15
Mandrel Assembly Breakdown	16
Pneumatic Assembly Breakdown	17
Alternate Mandrel Assembly	18
Warranty Information	19

Tools Required for Assembly

Phillips Screw Driver	Socket Set SAE
Allen Key Set SAE	Adjustable Wrench

SATSIM

Semi-Automatic Tire Stud Insertion Machine

ASSEMBLY INSTRUCTIONS (Refer to Figure 1)

STEP "A"

1. Secure Main Post (16) to SATSIM Base (18) using the four 3/8"x 3" socket head screws and nuts (17,20).

STEP "B"

1. Attach C-Frame assembly (1) to main post using two 4 1/2" x 1/2" Hex Head Bolts w/nuts (11).
2. Align holes in C-Frame with holes in the column to obtain desired working height.

STEP "C"

1. Connect Roller assembly (2) to C-Frame by inserting threaded shaft into swivel block.

STEP "D"

1. Attach Control Panel (22) to main post using four 1/4-20 x 1/2" screws (12).
2. Place foot pedal (21) at convenient location.

STEP "E"

1. Attach work tray (14) to bracket at the back of the main post using 1/2" x 3" bolt, nut and washers (13,15).

STEP "F"

1. Attach water bottle holder (9) to back of main post using two 10-24 x 1/2" screws (10).
2. Fill bottle (8) with clean water and place in holder.
3. Attach clear blue tubing to the nozzle of the water bottle. Refer to **Fig. 3**. Page 9.

STEP "G"

1. Insert feeder post (7) into hole at top of main post and tighten set screw.

STEP "H"

1. Attach lamp w/magnetic base (3) to right side of C-Frame.

STEP "I"

1. Connect feeder (5) w/optional motor (6) to top of feeder post
2. Connect clear plastic feeder hose (4) from feeder to input tube of SATSIM as per **Fig 3**. Cut to proper length.

PNEUMATIC CONNECTIONS

Connect the three air lines as per **Fig 2**. Page 9. The "Insert" pressure fitting and tubing is 8mm and *Black*. The "Stroke" Pressure is *Blue* and the "Retract" pressure is *Red*.

Note: Tubing may be connected or disconnected by pushing firmly on the plastic ring of the fitting and simultaneously inserting or removing the tubing.

FIGURE 1

ASSEMBLY DIAGRAM

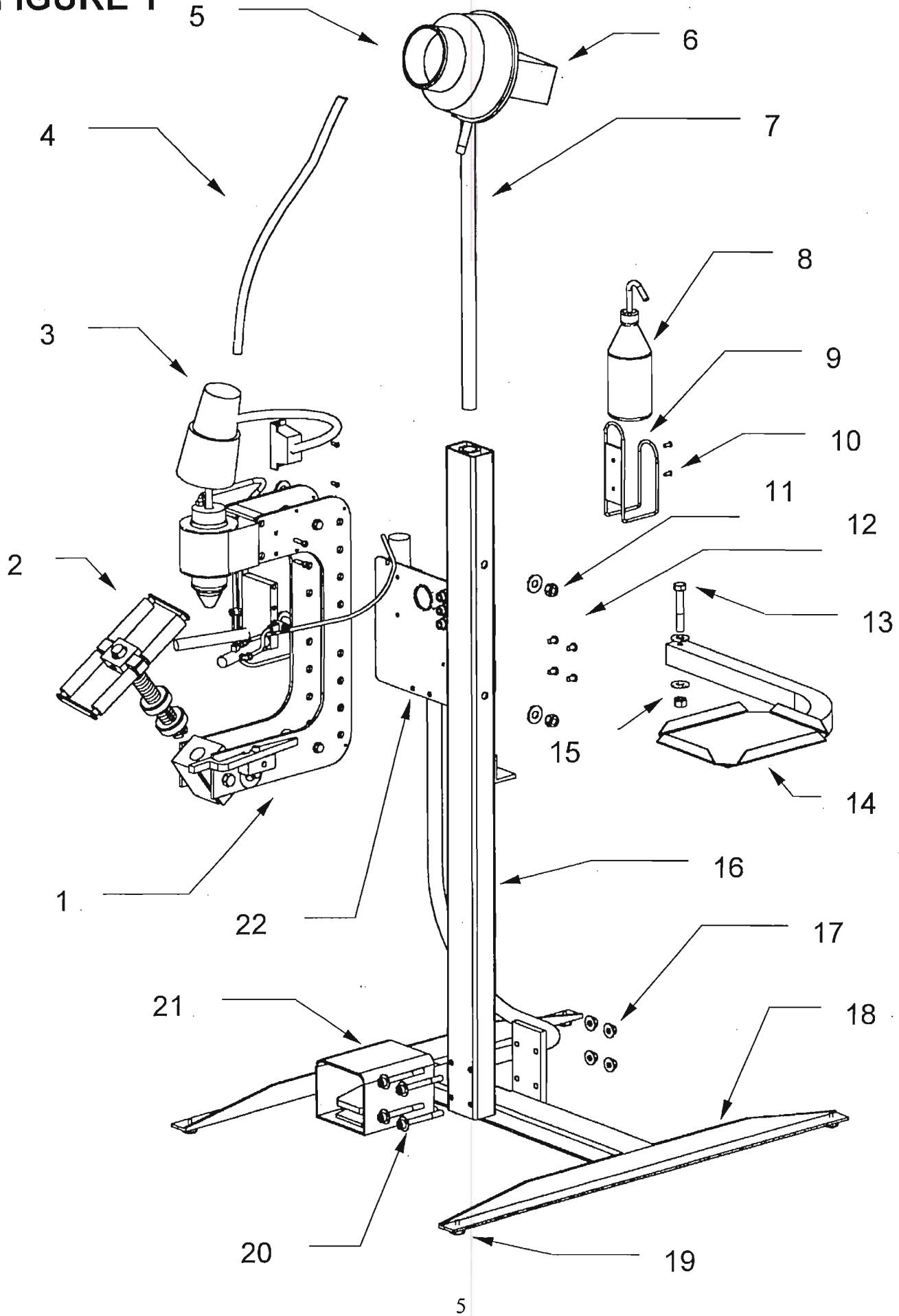

ROCKET SATSIM ASSEMBLY BREAKDOWN

ITEM	QUANTITY	PART NUMBER	DESCRIPTION
1	1	MFG 400101	C-Frame ASSY.
2	1	MFG 400106	Roller ASSY.
3	1	MFG 600112	Lamp ASSY.
4	1	STP 0161	Feed Hose 9mm
5	1	STE BWFP-9A	Feeder 9mm
6	1	STP 0177-110	Motor
7	1	MFG 100146	Feeder Post
8	1	MFG 200074	Water Bottle
9	1	MFG 200075	Bottle Holder
10	2	MFG 200104	10 - 24 Screws
11	2	MFG 200016	1/2 - 13 Nut
12	4	MFG 200015	1/4 - 20 Screws
13	1	MFG 200106	1/2 - 13 x 3" HHCS
14	1	MFG 400026	Tray ASSY.
15	1	MFG 200105	1/2 - 13 Washer
16	1	MFG 100005	Main Post
17	4	MFG 200018	3/8 - 16 Nut
18	1	MFG 400104	SATSIM Base
19	4	MFG 200103	Floor Levelers
20	4	MFG 200007	3/8 - 16 x 3" SHCS
21	1	MFG 300152	Foot Valve
22	1	MFG 400100	Pneumatic ASSY.

Helpful Hints and Recommendations:

Always inspect the common wear parts of the gun and feeder for excess wear **PRIOR** to beginning the studding procedure. **ONLY TRAINED PERSONNEL SHOULD SERVICE THIS EQUIPMENT. THE STEEL HEAD ASSEMBLY OF THE STUD GUNS IS SPRING LOADED. USE EXTREME CAUTION WHEN DISASSEMBLING.**

A properly installed stud should appear to be nearly flush with the tire surface. **Only the carbide pin and about 1/32" of the stud body should be visible.** Also, be sure that the stud is inserted straight into the hole. A leaning stud will not properly seat into the tire and will cause premature failure.

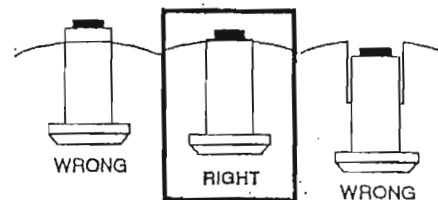
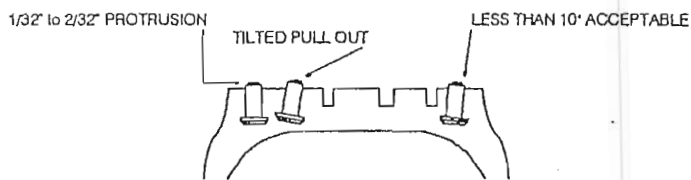

Advise the customer that the studded tires require require a break-in point. The customer should drive normally (try to avoid hard cornering, acceleration and braking) for a few days or so. (Approx. 50-100 miles) to allow for proper tire stud seating.

SATSIM MAINTENANCE

The SATSIM has been designed to require a minimum amount of owner maintenance. The modular design allows for the quick exchange of main assemblies. It is recommended that service on internal components be performed by factory trained personnel.

1. The SATSIM requires a clean dry input air supply. Working pressure is 90 -150 psi. (600 - 1000 kPa)

2. The air filter and lubricator use polycarbonate bowls. The maximum supply pressure for these bowls is 220 psi and maximum operating pressure is 150 psi. Regularly inspect these bowls for cracks or signs of brittleness. Polycarbonate bowls can be attacked by a wide variety of aggressive chemicals.

3. The air filter uses a manual drain system. To drain unit, remove air supply first. Drain unit by pressing button on the drain valve at the bottom of the filter. Regularly inspect for the presence of a large amount of fluid in the bowl as shown in the sight glass. If this occurs, **REMOVE INPUT AIR SUPPLY**, unscrew bowl, drain water and inspect filter elements for debris.

SAFETY: After any adjustment or maintenance has been carried out, ensure that all fittings and spacers are firmly attached and that all bowls are securely screwed into position,

4. Internal lubrication is provided by an oil lubricator. Recommended oil is ISO VG32. To add oil, remove input air supply, remove black screw at top of lubricator and fill bowl two-thirds full. Monitor oil supply regularly and fill when required. Adjust mist control on oiler to mid point.

5. Internal wearing items include parts common to many stud inserting tools. The majority of these parts are easily replaced by the operator. To access the internal parts, push up firmly on the tool head while unscrewing the retaining nut.

WARNING: Care should be taken when servicing this assembly as there is a strong internal spring maintaining pressure on the head.

6. If studs fail to install, check inserting fingers (part 0126) for wear or bending.

7. For service parts call your studding equipment distributor. For technical assistance, call 1-800-465-3464 in North America, or 01-519-452-1935 in Europe.

SATSIM

Semi-Automatic Tire Stud Insertion Machine

OPERATING INSTRUCTIONS

Inserting Finger Style Machine

1. Connect air supply to ¼" female fitting of regulator on control panel. The SATSIM works best with a supply of 120-150 PSI (8-10 BAR) of clean dry air.
2. Adjust regulator knob clockwise until gauge on front of control panel reads approximately 110 PSI (7.5 BAR).
3. Unlock and pivot the roller assembly to the forward position. This will allow a test of the unit and ensure the inserting fingers do not strike the anvil of the roller assembly.
4. Test unit by repeatedly stepping on the foot pedal. The head assembly should move in a downward direction and the inserting fingers should extend out of the head.
5. Step on the foot pedal and keep it pressed down. Adjust the water spray at the flow control. Loosen the lock-nut and adjust counter-clockwise for more spray. **See FIG 3.** Note: To start the flow of water, it may be necessary at first to prime the sprayer by squeezing the bottle and forcing a flow through the tube.
6. Release foot pedal and mount a tire onto the roller assembly. Move roller assembly forward into the locked position. Adjust the roller assembly so that the anvil is approximately 1/16" (1.5mm) from the rubber on the inside of the tire. The roller assembly is adjusted by raising or lowering the tire with the top elevating nut.
7. Use the bottom elevating nut to raise the tire until the external fingers are approximately 1/8" (3mm) from the tire tread.
8. Load stud feeder with the required size of studs and ensure the studs are flowing through the feed hose into the feed tube of the machine.
9. Line up the external fingers with a stud hole in the tire and operate the foot pedal. Release the foot pedal immediately after the stud is installed.
10. If the stud does not seem to be at the correct depth, adjust the main regulator on the control panel. The gauge on the front of the control panel will indicate the current operating pressure of the SATSIM. An increase in pressure will cause the studs to be inserted deeper.
WARNING: Do not adjust past 150 PSI (10 BAR)
11. Ensure the water spray is directed at the external fingers as they enter the stud hole. The direction of the spray can be adjusted by loosening the screw at the back of the spray guide.

FIGURE 2

OPERATING DIAGRAM

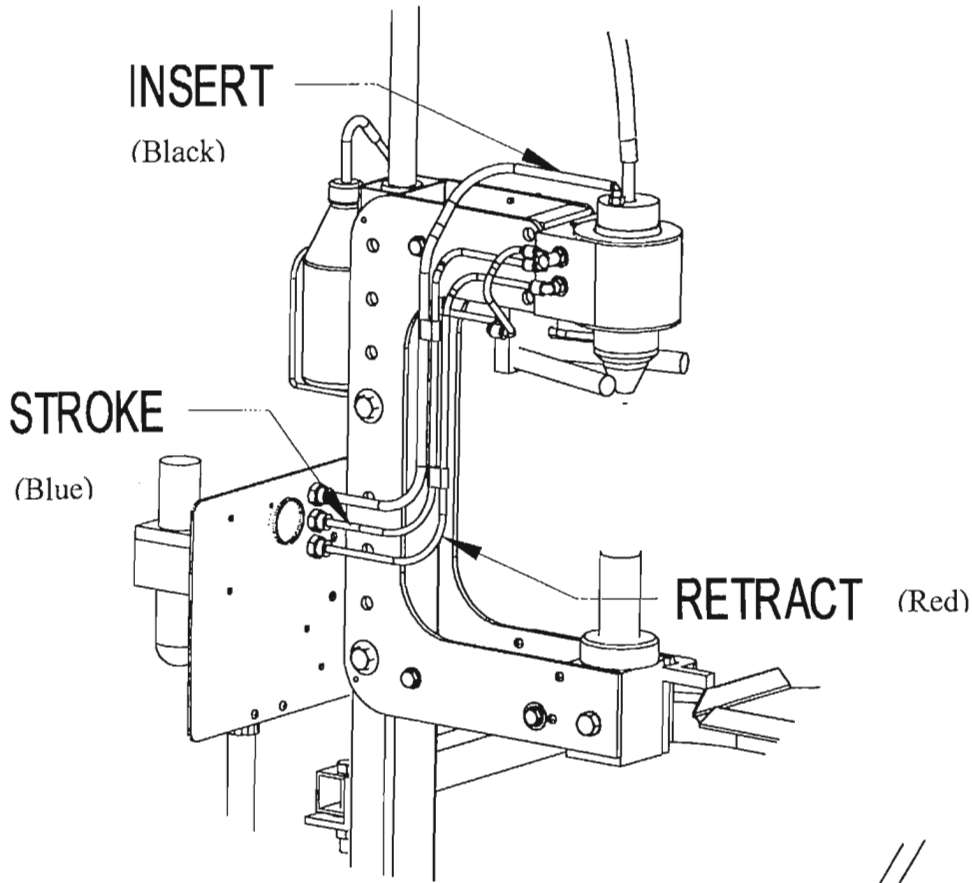

FIGURE 3

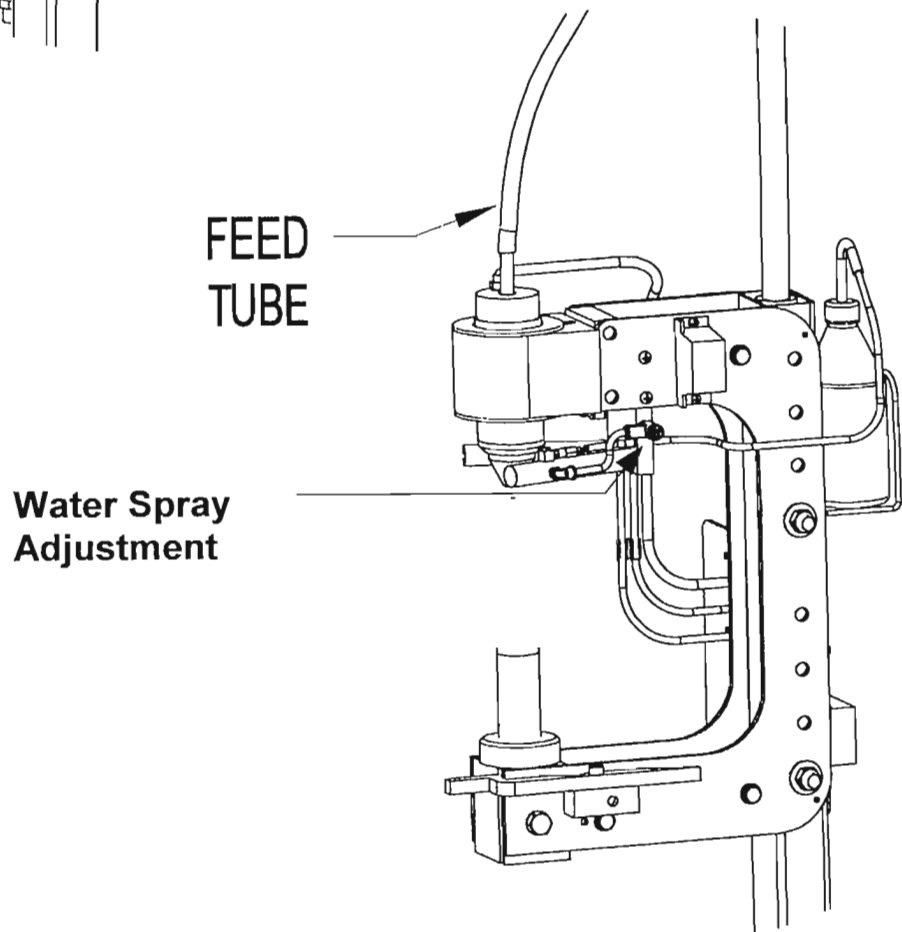

FIGURE 4 HEAD & SPRAY GUIDE ASSEMBLY BREAKDOWN

ITEM	QUANTITY	PART NUMBER	DESCRIPTION
1	1	MFG 100105	Guide Support Plate
2	2	MFG 200015	1/4-20 x 1/2" Screw
3	1	MFG 300122	Flow Control
4	1	MFG 300134	Check Valve and Fitting
5	1	MFG 300120	M5 x 6 Elbow
6	1	MFG 100101	Right Guide w/Water Spray
7	1	MFG 100104	Left Guide
8	2	MFG 200082	5/16 x 1" Hex Socket Cap Screw
9	1	STP 0136	O-Ring
10	1	MFG 100138	Feed Tube 9mm
10	1	MFG 100140	Feed Tube 8mm
11	1	STP 0383	Piston Cup
12	1	STP 0129	Piston
13	3	STP 0126	Inserting Finger
14	1	STP 0092	Piston Cup
15	1	STP 0135	Steel Ring
16	1	STP 0088	O-Ring
17	1	STP 0131	Tapered Cone
18	1	STP 0134	Compression Spring
19	1	STP 0132-09	Head 9mm
19	1	STP 0132-08	Head 8mm
20	3	STP 0127	Metering Lever
21	3	STP 0084	External Finger
22	1	STP 0087	O-Ring
23	1	STP 0133	Ring Nut
24	8	MFG 200014	10-24 x 1/2 Socket Head Screws
25	2	MFG 100143	Head Washer
26	2	MFG 200059	O-Ring
27	3	MFG 200061	O-Ring
28	1	MFG 100103	Lower Bearing
29	1	MFG 102003	Insertion Tool
30	1	MFG 300096	1/8-8 Elbow Fitting
31	1	MFG 102001	Cylinder Housing
32	1	MFG 100144	Upper Bearing
33	1	MFG 200090	Wiper Seal
34	2	MFG 200012	3/8 x 1" Socket Head Cap Screws
35	4	MFG 200001	1/2 x 5/8 Socket Head Shoulder Scr
36	1	MFG 102002	Guide Support Plate
37	1	MFG 300100	1/8-6 Y Fitting
38	1	MFG 300099	1/8-6 Elbow

HEAD & SPRAY GUIDE ASSEMBLY

FIGURE 4

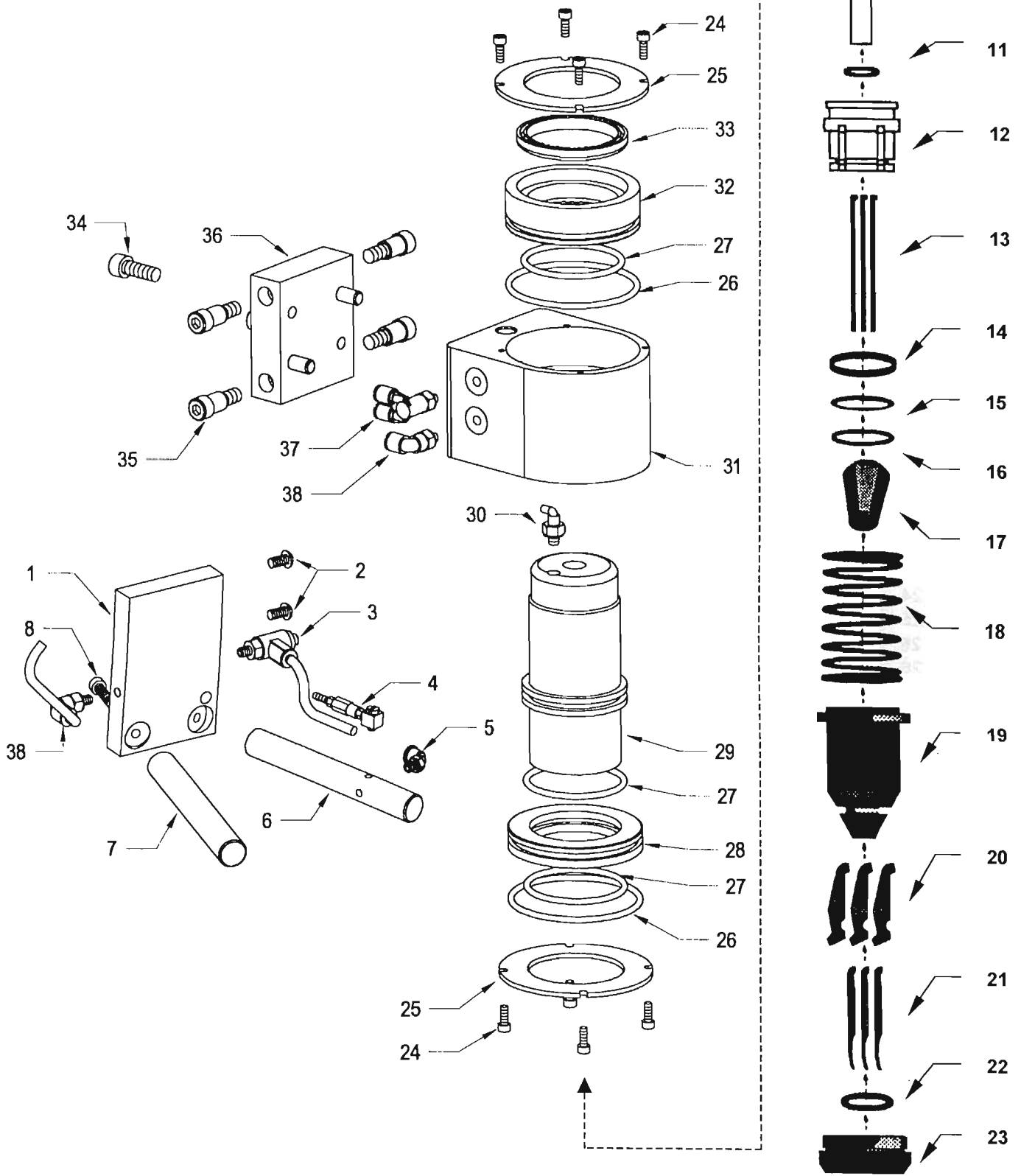

FIGURE 4B HEAD & SPRAY GUIDE ASSEMBLY BREAKDOWN

ITEM	QUANTITY	PART NUMBER	DESCRIPTION
1	1	MFG 100105	Guide Support Plate
2	2	MFG 200015	1/4-20 X 1/2 Screw
3	1	MFG 300122	Flow Control
4	1	MFG 300027	1/8 x 1/8 Barb Fitting
5	1	MFG 300134	Check Valve
6	1	MFG 300133	Banjo Fitting
7	1	MFG 300120	M5 x 6 Elbow
8	1	MFG 100101	Right Guide w/ Water Spray
9	1	MFG 100104	Left Guide
10	2	MFG 300099	1/8-6 Elbow
11	2	MFG 200082	5/16 x 1" Hex Socket Cap Screw
12	1	MFG 200009	Nut M-8
13	1	STP 0181	Piston Disc
14	1	STP 0092	Piston Cup
15	1	STP 0183	Piston Rod 8mm
15	1	STP 0184	Piston Rod 9mm
16	1	STP 0200	Spring Set
17	1	MFG 100151	Holding Ring
18	1	STP 0195	Retaining Ring
19	1	STP 0186	Feed Tube 8mm
19	1	STP 0187	Feed Tube 9mm
20	1	MFG 102017	Mid Section
21	1	MFG 200010	Set Screw
22	2	MFG 200011	Screw
23	1	STP 0197	Spring Ring
24	1	STP 0193	Head 8mm
24	1	STP 0194	Head 9mm
25	1	STP 0191	Release Lever
25	1	STP 10210	Release Lever Mult-Flange
26	1	STP 0192	Pin
27	1	STP 0195	O-Ring
28	1	STP 0087	O-Ring
29	3	STP 0196	Guide Fingers
30	3	STP 0084	External Fingers
31	1	STP 0189	Ring Nut
32	8	MFG 200014	10-24 x 1/2 Socket Head Screws
33	2	MFG 100143	Head Washer
34	2	MFG 200050	O-Ring
35	3	MFG 200061	O-Ring
36	1	MFG 100103	Lower Bearing
37	1	MFG 103003	Insertion Tool Long
38	1	MFG 300096	1/8-8 Elbow
39	1	MFG 300100	1/8-6 Y Fitting
40	1	MFG 102001	Cylinder Housing
41	1	MFG 100144	Upper Bearing
42	1	MFG 200090	Wiper Seal
43	1	MFG 102014	Stop Plate
44	2	MFG 200004	1/4-20 x 3/4 Screw
45	1	MFG 102015	Knob
46	1	MFG 102012	Threaded Stop Rod
47	1	MFG 200086	Wing Nut

HEAD & SPRAY GUIDE ASSEMBLY

FIGURE 4B

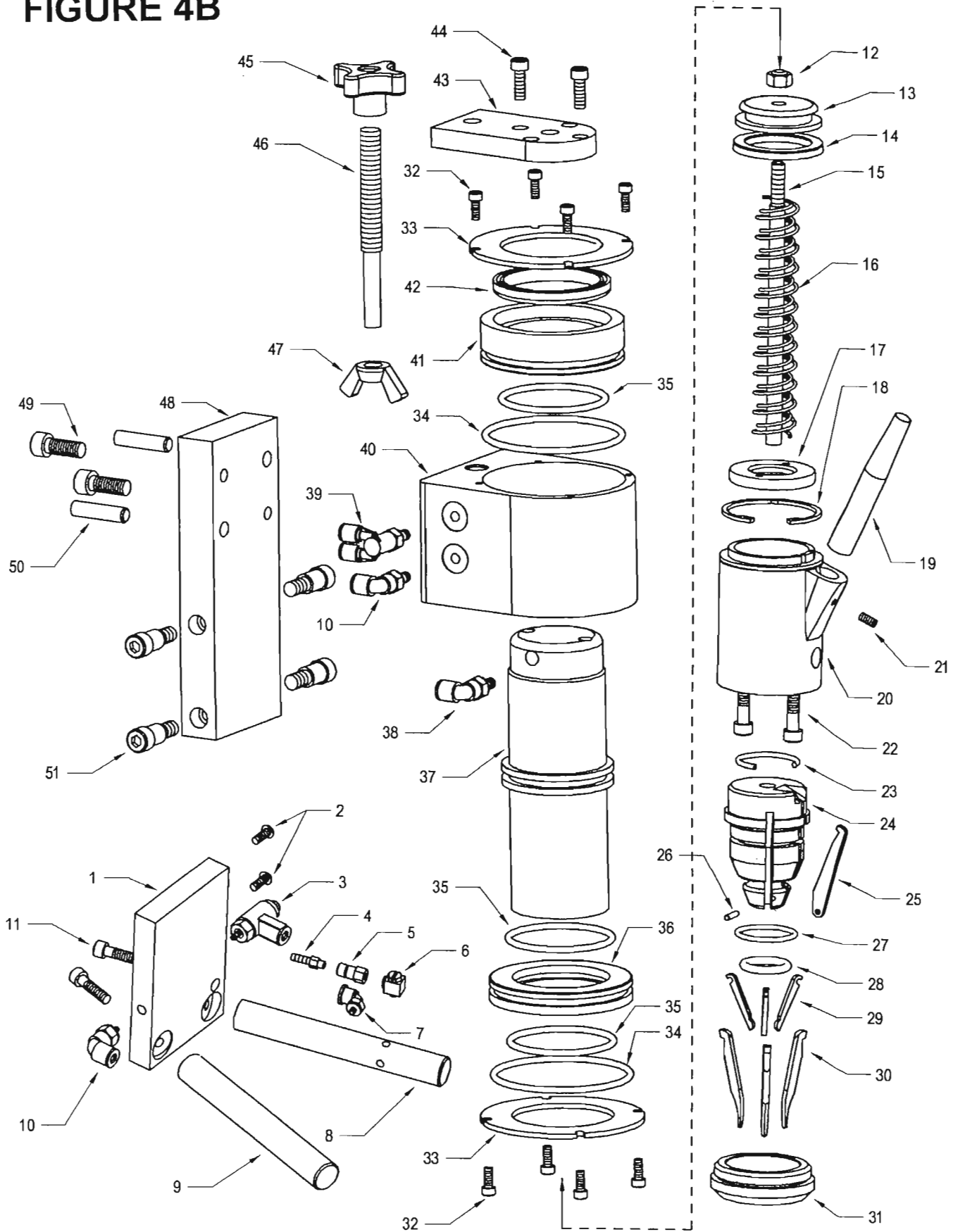

FIGURE 5 C-FRAME ASSEMBLY BREAKDOWN

ITEM	QUANTITY	PART No.	DESCRIPTION
1	1	MFG 103000	Frame LH Steel
2	1	MFG 102000	Frame RH Steel
3	3	MFG 102008	Spacer C-Frame
4	7	MFG 200019	Washer 3/8"
5	7	MFG 200092	3/8 x 1 1/4 " HHCS
6	4	MFG 200024	Washer 1/2"
7	2	MFG 200016	1/2" Nut
8	1	MFG 200079	3/8 x 1" Socket Head Shoulder Screw
9	1	MFG 200084	Spring
10	1	MFG 100115	Locking Lever
11	1	MFG 100114	Mounting Block, Locking Lever
12	4	MFG 200002	1/4"-20 x 1/2" Screws
13	2	MFG 102010	Shoulder Bolts, machined
14	2	MFG 102013	Plastic Bushings
15	2	MFG 100113	Thrust Washers
16	1	MFG 100116	Swivel Block
17	2	MFG 102009	Stop Rod
18	1	MFG 200015	1/4-20 x 1/2 Phillips
19	2	MFG 200013	1/2-13 x 4 1/2" HHCS

FIGURE 5

C-FRAME ASSEMBLY

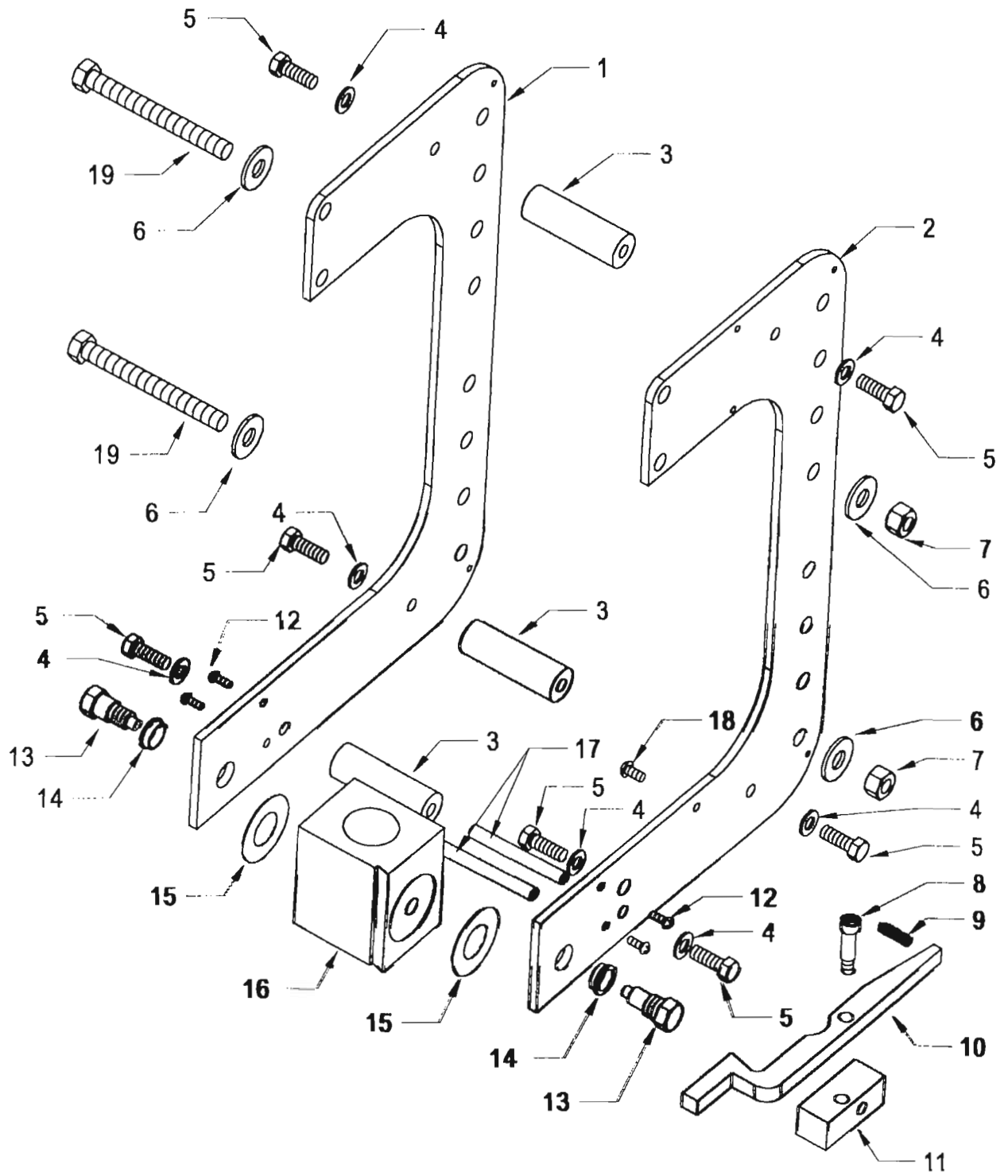

FIGURE 6 MANDREL ASSEMBLY BREAKDOWN

ITEM	QUANTITY	PART NUMBER	DESCRIPTION
1	1	MFG 100118	Elevating Rod Threaded
2	2	MFG 100131	Elevating Nut
3	4	MFG 200015	1/4-20 x 1/2" Screws
4	2	MFG 100147	Bracket
5	4	MFG 100148	Roller
6	2	MFG 100145	Swivel Blocks
7	1	MFG 100146	Center Block
8	1	MFG 100150	3/8" Machined Bolt
9	2	MFG 100149	Rod

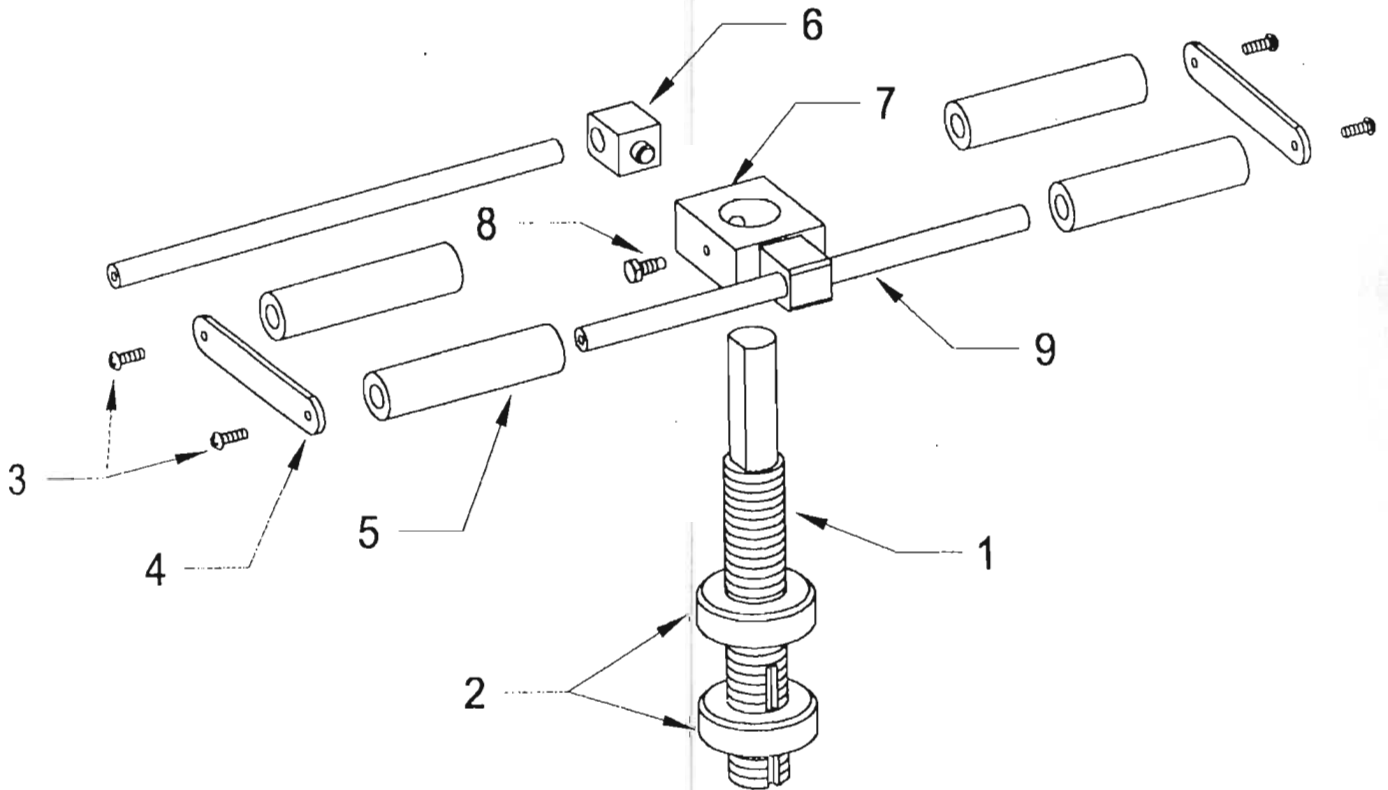

FIGURE 6

FIGURE 7 PNEUMATIC ASSEMBLY BREAKDOWN

ITEM	QUANTITY	PART NUMBER	DESCRIPTION
1	1	MFG 300116	Conduit Bracket
2	1	MFG 300113	Conduit
3	1	MFG 300115	Bracket Nut
4	1	MFG 300154	Control Valve
5	1	MFG 300112	Muffler
6	1	MFG 300111	Pressure Gauge
7	1	MFG 300078	Oiler
8	1	MFG 300077	Filter/Regulator

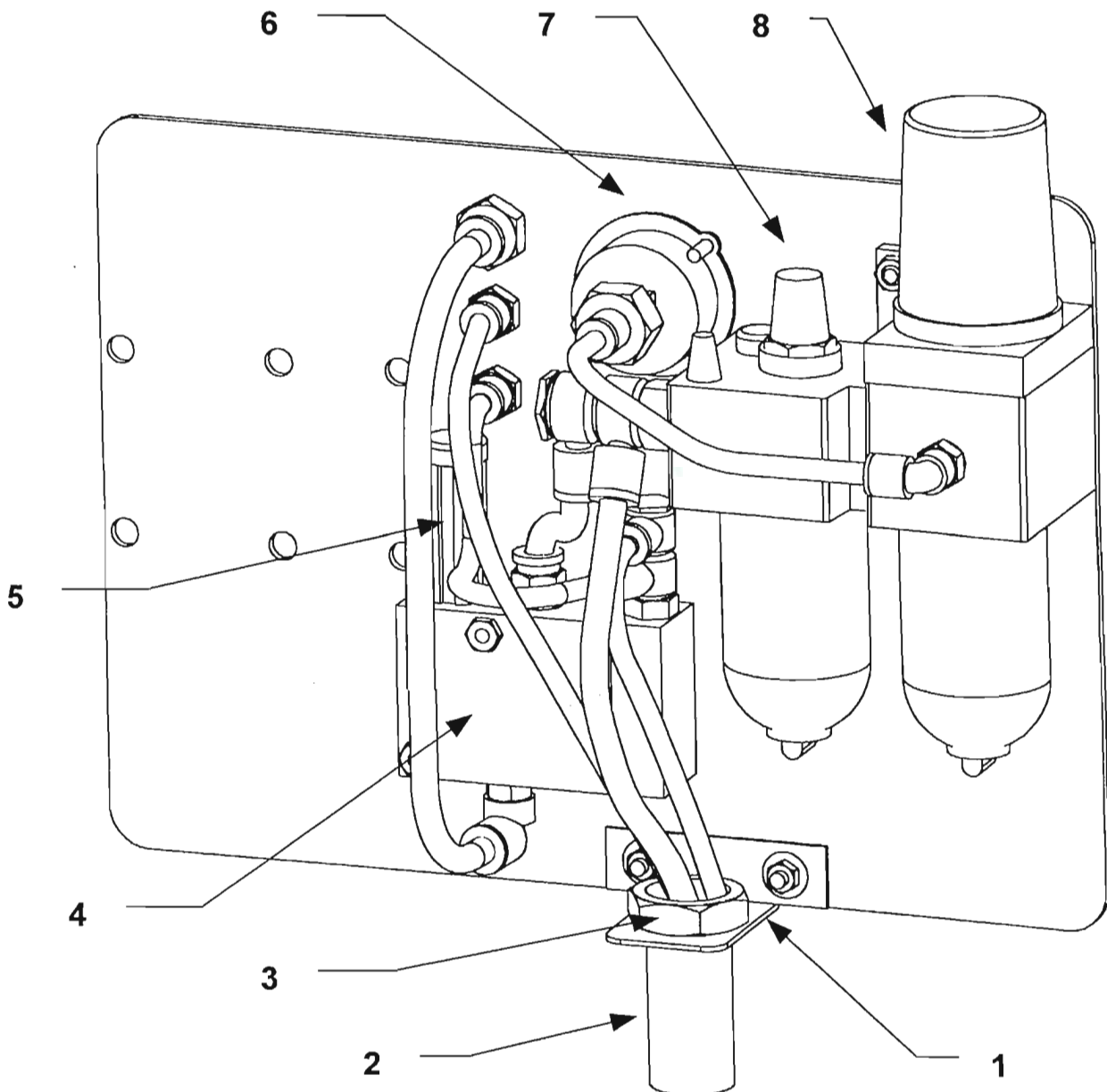

FIGURE 7

FIGURE 8 ALTERNATE MANDREL ASSEMBLY BREAKDOWN

ITEM	QUANTITY	PART NUMBER	DESCRIPTION
1	4	MFG 200067	Ball Transfer
2	1	MFG 100117	Ball Transfer Platform
3	2	MFG 200052	Set Screw
4	4	MFG 200093	5/16" Locknut
5	1	MFG 100118	Elevating Rod
6	1	MFG 100131	Elevating Nut

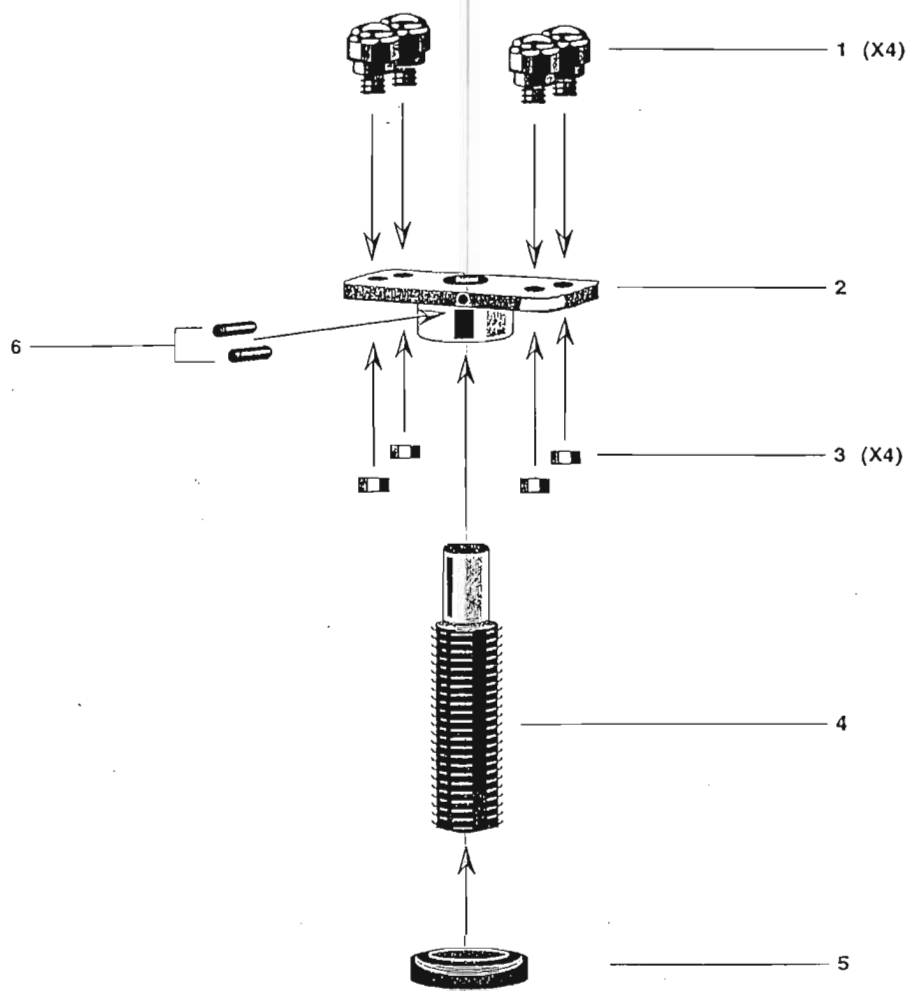

FIGURE 8

COMMERCIAL WARRANTY

This equipment is warranted by Bruno Wessel, Ltd., to the original end user, against defects in materials or workmanship, for a period of one (1) year from date of purchase (90 days for hoses, gauges and hose chucks). During the warranty period, any equipment found to be defective will be repaired or replaced (at factory's option) without charge.

To request warranty service, you must contact the factory. If the equipment must be returned, then a warranty registration number (WRN) will be issued. This WRN must be shown on all shipping labels and shipping documents. The equipment must be shipped with the transportation charges fully prepaid. The equipment will be repaired or replaced and returned at factory's expense. Any equipment returned without following this procedure will be refused.

This warranty does not cover defects caused by ordinary wear and tear, abuse, misuse, overloading, accident, shipping damage, improper maintenance, alteration, use with improper fluids or fluid levels, improper or contaminated air supply, or any other cause not the result of defective materials or workmanship.

Any equipment that is repaired or replaced, within the warranty period, shall not extend the original warranty period. Any purchased service part that is defective in materials or workmanship will be repaired or replaced by the factory, if so defective within 90 days of purchase.

REPAIR OR REPLACEMENT IS THE EXCLUSIVE REMEDY FOR DEFECTIVE EQUIPMENT UNDER THIS WARRANTY. THIS WARRANTY IS EXPRESSLY IN LIEU OF ALL OTHER WARRANTIES, INCLUDING ANY IMPLIED WARRANTY OF MERCHANTABILITY OR FITNESS FOR A PARTICULAR PURPOSE.



BRUNO WESSEL

**BRUNO WESSEL INC.
IN USA**

1-800-869-1908
Tel. (914) 381-7771
Fax (914) 381-7775

**BRUNO WESSEL LTD.
IN CANADA**

1-877-452-1935
Tel. (519) 452-1935
Fax (519) 452-3911